

ME A403 Machine Design**Fall 2021****Quiz 3****Assigned:** October 27, 2021**Due:** 23:59 October 31, 2021

This quiz is worth 100 points (10 % of total grade). This is an individual assignment. You may use the textbook, lecture notes, and other sources listed in the assignment. No collaboration between students or consultation with any other persons are allowed.

All submissions must be uploaded to the Blackboard. Make sure to include and submit all of your work: hand calculations, sketches, computer code, spreadsheets, SolidWorks files, etc. (anything you have created while completing the assignment).

You must fill out and sign the honor pledge below. Make sure to submit this page with the signed pledge with your assignment.

By typing/writing your name in the space below, you are signing the following pledge:

"I pledge that I have neither given nor received any unauthorized assistance during this examination."

NAME:

Consider a stepped round bar shown in Figure 1. It is welded at the left end and loaded with a constant transverse force F and a torque T applied at the face on the free end. Design the bar (determine the diameter d) to achieve a factor of safety $n = 2.5$. The bar is made of AISI 1010 hot-rolled steel.

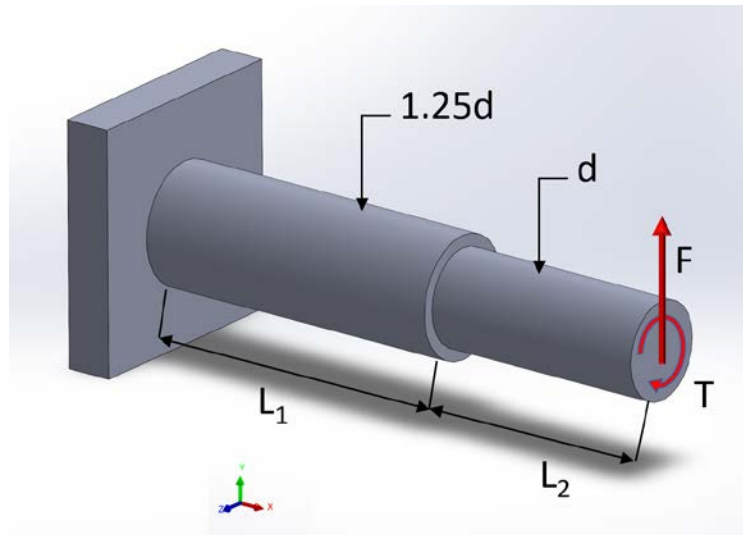

Figure 1: Bar schematic.

Consider the last four digits of your student ID number: $D1 D2 D3 D4$. The problem parameters are defined as shown in Table 1.

Table 1: Definition of problem parameters.

Parameter	Distance L_1	Distance L_2	Force F	Torque T
Value	$8+0.1*D1$	$4.0+0.1*D2$	$150+10*D3$	$150+10*D4$
Units	in	in	lbf	lbf-in

For example, the last four digits are: 4359, then: $L_1 = 8+0.1*4 = 8.4$ in, $L_2 = 4.0+0.1*3 = 4.3$ in, $F = 150 + 10*5 = 200$ lbf, and $T = 150 + 10*9 = 240$ lbf-in.

There are 3 parts to this assignment:

Part a) (60 points) Select and justify an appropriate failure criterion and determine diameter “ d ” to achieve the required factor of safety. Make sure to use the preferred sizes from Table A-17. You may write a MATLAB live script or develop a spreadsheet for convenience. Make sure to draw necessary diagrams (FBD, V , M , etc.,) and show all of your equations, calculations, or code.

Part b) (10 points) Having obtained the diameter “ d ”, determine the von-Mises stress at the critical location on the bar.

Part b) (30 points) Create a model of the bar with the fixed end in SolidWorks. Perform a mesh convergence study in SolidWorks to verify the value of the von-Mises stress computed in part b). You

will need to apply the mesh control to the face/edge at the critical location. Does the numerical solution converge? Please watch the video tutorial via the link below.

<https://alaska.zoom.us/rec/share/ORnrxG16BNJWsbyTbdnJQ6Lio2aqcQxMwo2RqdBTMUKWz5OwZ4OyiPyYPBzS4mf.hhFO7eYiuiXY65Jt>

Passcode: H.zvcJ&1